

HOW TO BUILD AN EARTHQUAKE EMERGENCY SHELTER

1. INTRODUCTION

After a disaster such as an earthquake especially small children are weakened by lack of food, appropriate healthcare and save shelter.

Therefore the Earthquake Shelter is developed. The shelter is build out of very cheap and materials that are simple to transport. It is designed within the framework of healthcare provision following the WHO-guidelines, and agreed upon by the members of the UN.

The house has a simple design so that people can construct this facility themselves. Offered below is the material kit and clear instructions on how to build this shelter.

2. MATERIAL KIT

(shelter for 72 people)

All materials that are needed to construct the house need to be rolled up or folded, in order to take the least amount of space during transportation. Alternative and additional materials can be collected from the site.

Walls : -Strong Bags, 70 kg weight. (Rice or sand bags, any other kind of bag) -Isolating aluminium foil. (Radiator foil, aluminium household foil) -Outside wall=900 bags. -Inside walls= 600 bags. Total=1500 bags	Insulation : -Plastic foam. -Plastic bags. -450 square meter isolating aluminium foil. -Old paper, textile, dry leaves.	
Roof : -Plastic or water proof canvas. Minimum width 6 meter, length may vary. 300 square meter -Iron or plastic rope lines 550 meter	Connections : -Strong tape -Glass fibre tape. 600 meter	Opening : Blanket or quilt.

3. THE EARTHQUAKE EMERGENCY SHELTER

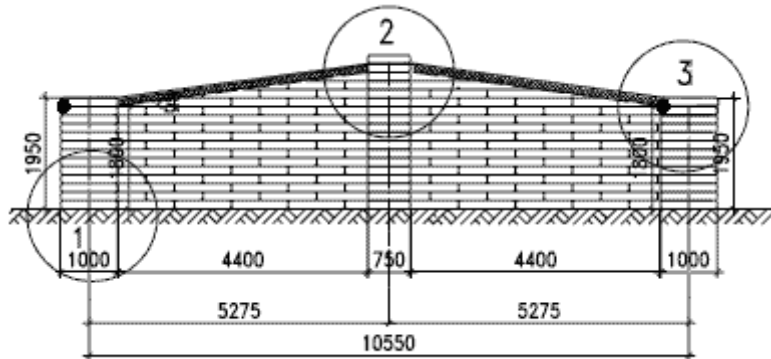

The house is made from simple materials such as sand bags, rope lines, tape and available isolation materials.

The construction process begins by filling the sand bags with fine and heavy materials, as much as possible. It is important to make sure that the inner wall is higher than the outside wall.

After the walls are finished, the rope can be tightened between the walls. To connect the rope, loop the ends around the two highest bags and use the weight of the bags to support the roof construction.

Accordingly put the canvas around the bags and tighten them between the last and second last bag.

After the construction shell is completed, the isolation can start. This is done from the inside, by fastening the available isolation material to the ceiling or between the ropes. The isolation is taped closed from the outside air with isolating aluminium foil. Below are more detailed instructions about each construction part.

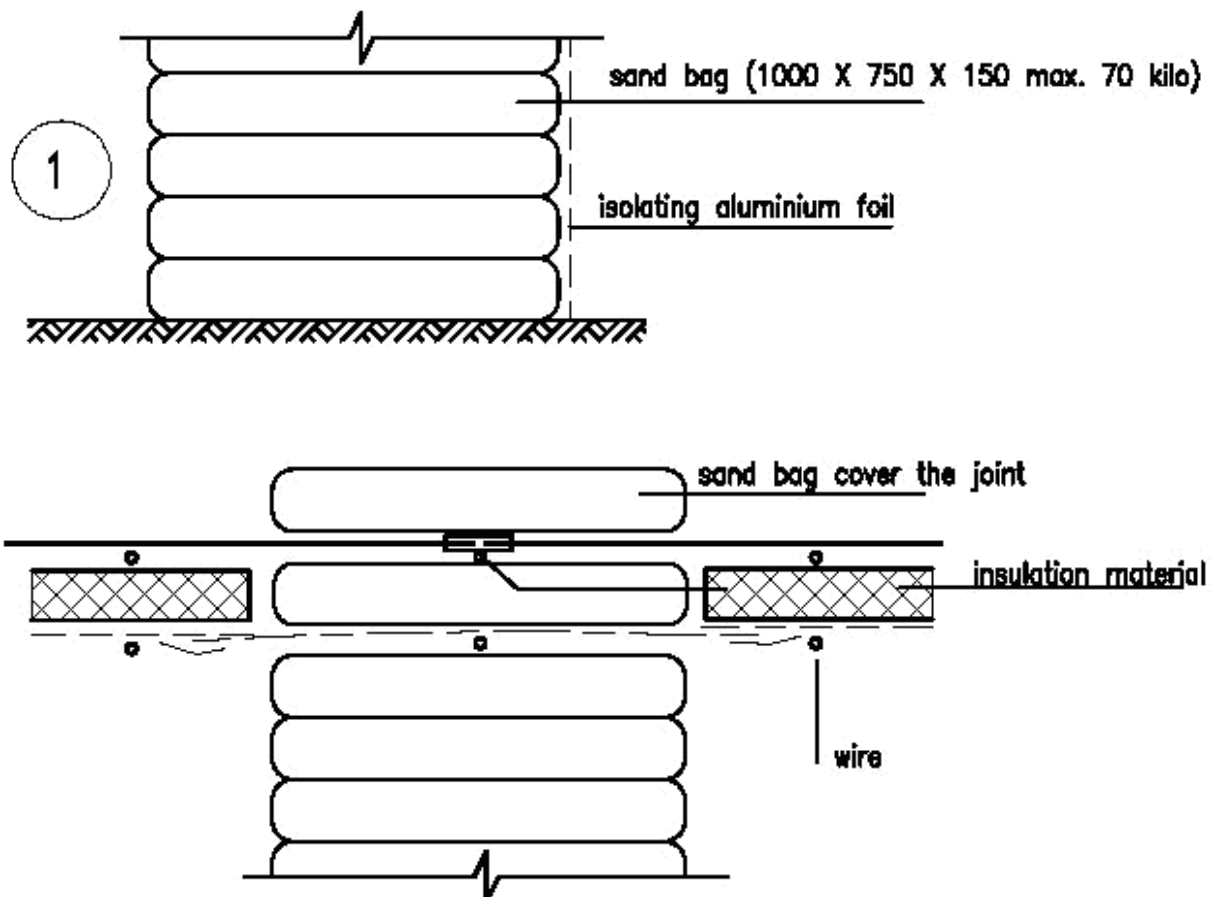

4. THE WALLS

The walls are built out of sand bags, max. 75 x 100 cm, which are strong enough to carry approximately 70 kg. This weight is acceptable for two persons to lift. Materials from the collapsed houses in the area may also be used.

It is important to break down these materials as fine as possible with a hammer. The finer the material inside the bag, the more stable the construction. After the bags are filled, they can be closed with ropes.

The next step is to stack these bags on to each other like bricks to create the walls of the shelter. It is very important to stack the bags in a cross-bandage pattern, to create stability of the wall construction. With cross-bandage, the second layer is always starting on the half of the bag which is below.

The corners must be constructed in cross-bandage pattern as well.

Extra strength can be reached by looping (iron) rope around the corners of the bags. An alternative can be to connect the bags with mortar at the corners. This will give more stability on the total construction.

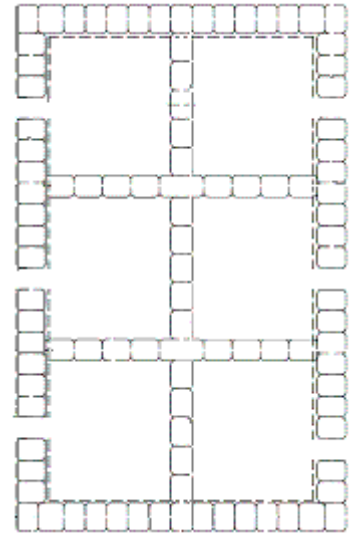

The size

In the long direction, the walls can be placed 4.4 meter from each other. This offers a place for two rows of beds in the long direction and enough room to walk. With 4.4 meter inner space, the inner wall is always higher than the outside wall. Here, a roof slope of approximately 4- 8 %, which is equal to 60 cm (4 sand bags), with a span of 4.4 m.

The canvas has to be spanned over the width (or short side) of the walls. This is best accomplished by connecting pieces of canvas on a sand bag wall.

Above this connection, you can place a sand bag or tape a piece of canvas. This makes the connection waterproof.

For the best isolation and earthquake stability of the walls, we recommend to put the longest side of the bag on the outside of the construction, use as much as possible. This gives the wall the highest isolation level and highest stability against new aftershocks. For the inner walls you can use the shortest side of the bag. These inner walls give the outside walls more stability.

Floor plan possibilities

With these walls, various configuration schemes for floor plans are possible. We recommend arranging the living units together, as much as possible. This will save on materials and create more stability for the construction.

Depending on the materials which are available on the site, the living units can be build up with additional constructions to shorten the distance of the construction span. If there is no construction material available in the environment the units are build up by four walls of sand bags.

If there are construction materials available in the environment, like wooden and iron beams, then it is possible to enlarge the floor space, creating greater spans thus saving more materials for other houses. These construction beams can replace one sand bag wall. Construction elements can be out of wood or iron beams.

These elements can be put in a hole, which is dug into the ground. The hole can be filled with available mortar, so the construction doesn't collapse quickly. It is important that rope will be span from the additional construction to the side walls of the house. This creates an extra span, which can carry the canvas. Through the extra construction a larger span is possible between the sand bag walls. Accordingly, rope lines can be spanned in the direction of the short side of the construction. This will offer support to carry snow and rain. Thus, the canvas will have the ability to carry more weight and will sag less inside, by the weight of snow and rain.

Improve the isolation of the walls

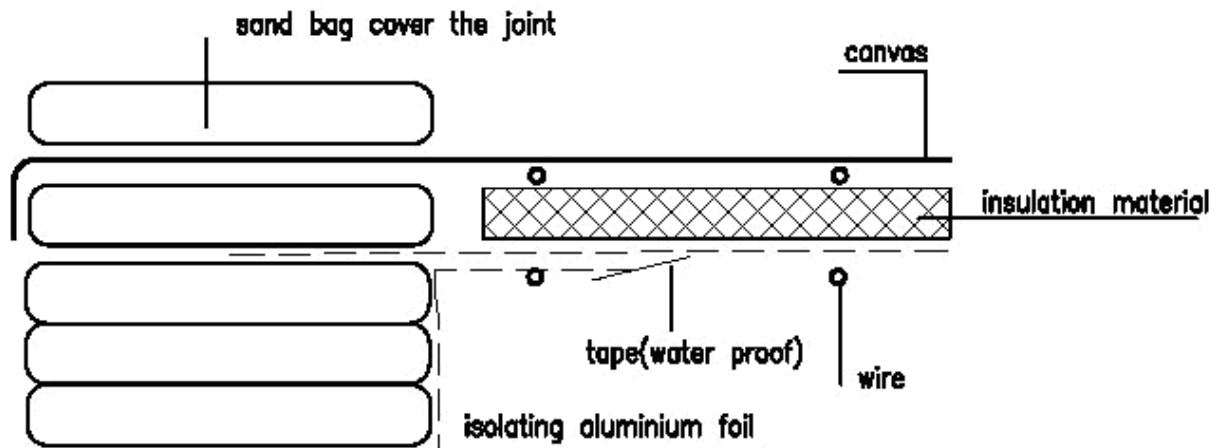

The isolation of the walls can be improved by isolating on the inside of the house with aluminium foil, isolation foil or radiator foil. These materials are taped to the walls. It is important as the tape seals the outside air passing to the inside. The foil reflects heat and warmth that is produce inside and keeps it inside. Other holes can be filled with paper.

Openings in the walls

It is very important not to put heavy materials above the openings in the walls, these can collapse during aftershocks. For more stability at the openings in the walls, side constructions can be used. In between the last two sand bags of the opening of the wall, place a wooden beam. Around this beam a blanket can hanged to close the opening. If you do this double on the out and inner side of the opening, extra isolation can be reached.

Ventilation possibilities in the walls

To circulate and ventilate the air in or between the spaces the leftover cardboard tubes from the aluminium foil rolls can be embedded in the walls, thus creating a small ventilation opening between walls.

5. THE ROOF

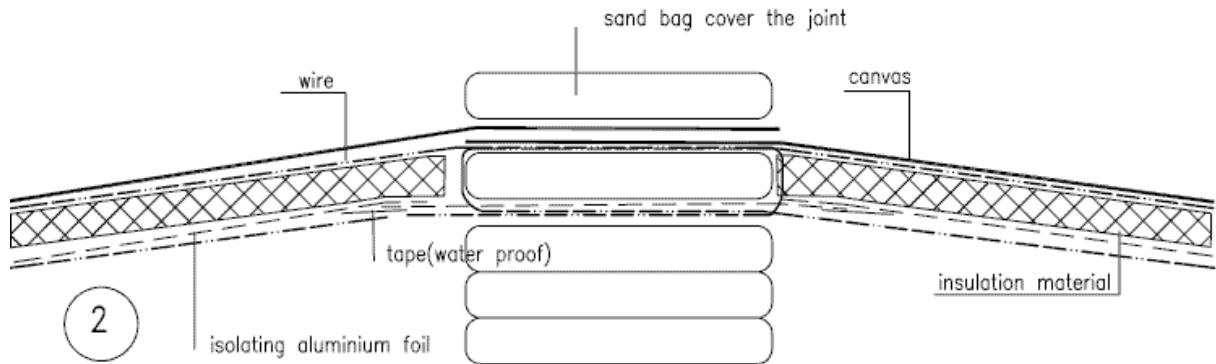

The roof is constructed out of plastic canvas or tent materials. The canvas can be constructed over the sand bags in the shortest direction of the construction 4.4m. The roof slope of approximately 4 - 8% is important so the snow can stay on the roof and create extra isolation for the shelter. To hold the construction the canvas is spanned between the second and last bag on both sides. For holding the weight of, for example, snow, extra ropes can be spanned between the bags. These ropes offers two advantages: the ropes can enlarge the size of the construction length and it can be used to carry the more heavy isolation materials, like an old bed mattress or other materials available on the site. These materials can be put in between the ropes without putting more weight on the canvas.

6. INSULATION POSSIBILITIES

To isolate the roof, many options are possible. It is important that these materials are light in weight. This is important because in case of after shocks, people are not hurt by anything that may fall down. Therefore we suggest some isolation possibilities. It is important that if there are more layers of isolation, the tape pattern should be cross-bandage to as little heat as possible. The escape of heat is so reduced at connection place of the tape.

Airbed insulation

The insulation can be created by airbeds. These airbeds weigh less, can be easily transported and can be taped to the ceiling or put in between the ropes. Accordingly, to which degree the roof needs to be isolated, more layers of airbeds can be stacked on each other. Every layer can be covered underneath with aluminium materials to reflect the warm back to the inside. The corners between roof and wall need to be taped air proof, so that there are no openings left.

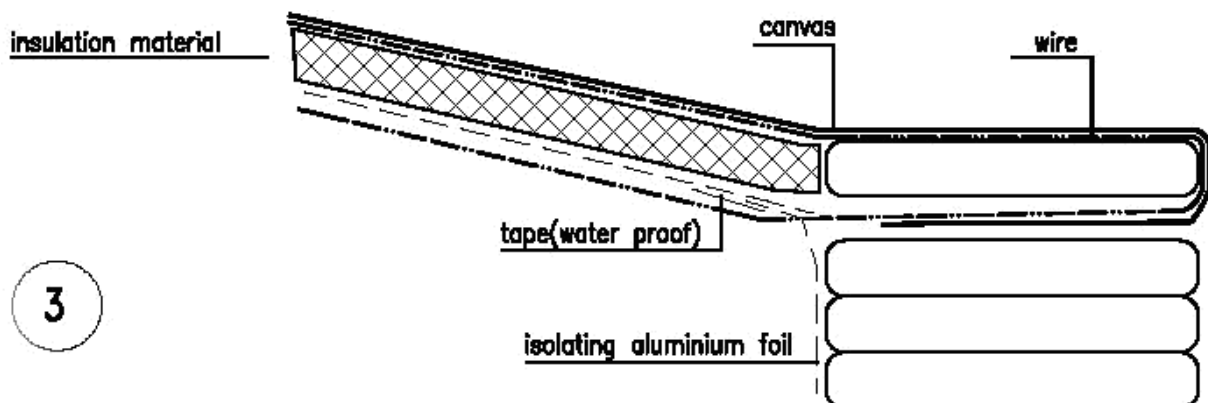

Paper or wool insulation

The best isolation way is the low-tech solution and exists out the cheapest materials. Here we use plastic bags, which can be filled by isolating material, like bundles of paper and textile materials. These bags can be taped to the ceiling. Different layers of these bags are necessary to create the right isolation level. If each different layer is covered with a layer of aluminium foil, a high isolation degree can be reached. This is the cheapest solution. Another alternative material for plastic bags can be plastic foam wrap, which is used as packing material. These plastic foam wraps have a better isolation value and can be delivered on.

Old bed or furniture material isolation

If there are extra rope constructions available, old beds or other high isolating materials which are heavier but soft, can put between the rope construction. These materials might be found at the site. The packet can be closed with isolating aluminium foil or be taped.

7. DETAILS

Connection wall to roof

It is important that there are no leaks of warmth between the connection of the wall and roof. Therefore we recommend to put some isolating aluminium foil between the last and second last bag which can be taped to the ceiling. Note wires above and below the insulation.

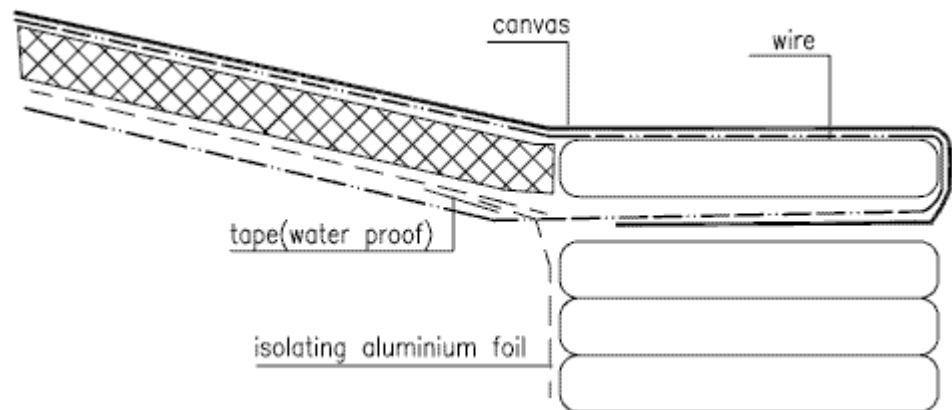

Connection canvas / canvas

To fasten the pieces of canvas to each other in the long direction can be done in different manners. We can nit the canvas with small ropes or lines if there are holes on the sides of the canvas. On top of this connection we can put a sand bag or tape another peace of canvas.

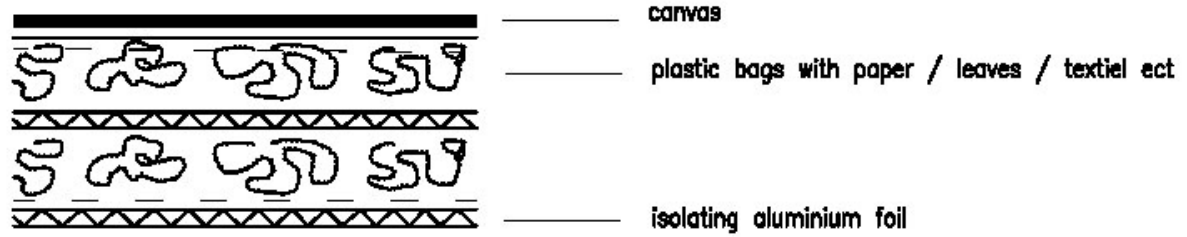
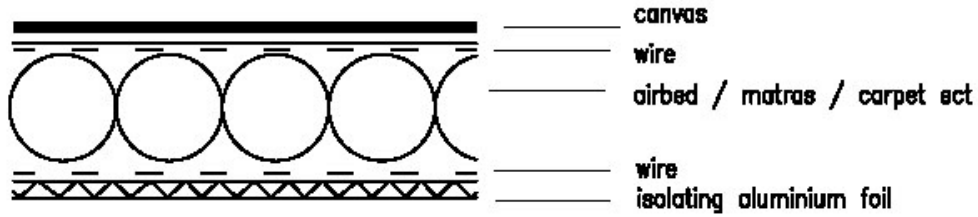

Bed and furniture

Beds can also be created by the sand bags. These can be filled with dry leaves, which can create an extra warm floor place to sleep on. Seat bags can be created in the same way.

Links to pdf files with master design drawings

[Scale drawing plans of emergency shelter](#) 125k

[Details of emergency shelter construction](#) 69k